



**OWNER'S (OPERATOR'S) MANUAL
AND SAFETY INSTRUCTIONS
FOR KITO PLAIN AND GEARED TROLLEY
TS SERIES**

ALWAYS SAVE THIS BOOK FOR FUTURE REFERENCE.

CONTENTS

1. DEFINITIONS	1
2. INTENDED PURPOSE	1
3. BEFORE USE	1
3.1 Safety summary	1
3.2 Safety instructions	2
4. MAIN SPECIFICATIONS	4
5. INSTALLATION	6
5.1 Coupling with manual chain hoists	6
5.2 Coupling with electric chain hoists	7
5.3 Adjusting trolley width before installation	9
5.4 Installation of trolley onto beam	9
5.5 Installation of stopper onto traversing beam	10
5.6 Check points after installation	10
6. OPERATION	10
6.1 Intended purpose of trolley operation	10
6.2 Safety working environment	10
6.3 Operation	10
6.4 Trolley storage	11
7. INSPECTION	11
7.1 Outline	11
7.2 Daily inspection	11
7.3 Periodic inspection	12
8. MAINTENANCE	15
8.1 Lubrication	15
8.2 Overhaul and assembly	15
9. OPTIONAL BUFFER	17
9.1 Buffer	17
10. WARRANTY	18
11. PARTS LIST	19

1. DEFINITIONS

⚠ WARNING : indicates a potentially hazardous situation which, if not avoided, could result in death or serious injury.

⚠ CAUTION : indicates a potentially hazardous situation which, if not avoided, may result in minor or moderate injury. It may also be used to alert against unsafe practices.

WLL : indicates maximum mass (working load limit) which a trolley is designed to support in general service.

2. INTENDED PURPOSE

This trolley is designed for horizontally transporting loads by hand, through manual or electric hoist under normal atmospheric conditions of the work place.

3. BEFORE USE

3.1 Safety summary

Danger exists when heavy loads are transported, particularly when the equipment is not being used properly or is poorly maintained. Because accidents and serious injury could result, special safety precautions apply to the operation, maintenance and inspection of the KITO plain and geared trolley TS series.

⚠ WARNING

- NEVER** use a trolley for transporting people. -----
- NEVER** transport loads over or near people.-----
- NEVER** transport more than WLL which is shown on the name plate. -----
- ALWAYS** let people around you know when a transport is about to begin.-----
- ALWAYS** read the operation and safety instructions. -----

Remember proper handling techniques are the responsibility of the operator. Check all applicable safety codes, regulations and other applicable laws for further information about the safe use of your trolley.

More detailed safety information is contained in the following pages. For additional information, please contact KITO Corporation or your authorized KITO dealer.

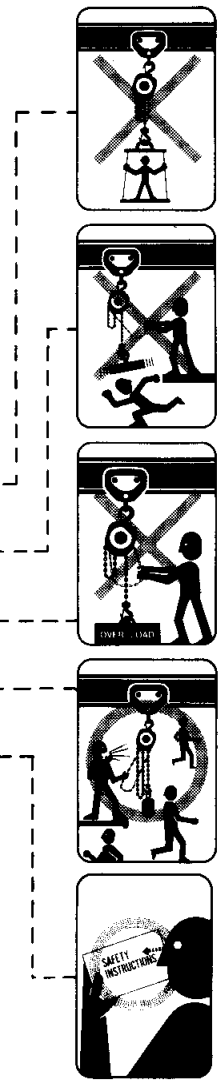

3.2 Safety instructions

⚠ WARNING

If this trolley is used in conjunction with a hoist, also refer to the hoist manual for additional precautions and instructions.

3.2.1 Before use

ALWAYS allow the instructed (trained in safety and operation) people to operate the trolley.

ALWAYS oil the trolley regularly (Refer to 8.1).

ALWAYS rig the load properly and carefully.

ALWAYS check the trolley according to the "Daily inspection" (Refer to 7.2).

NEVER use a trolley if the width does not fit the rail. -----

NEVER connect the hoist to the trolley with improper fittings. -----

NEVER use a trolley without a name plate.

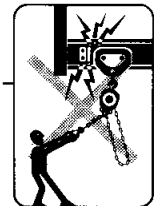

3.2.2 While operation

ALWAYS make sure that the load does not get in a way of hand chain.

NEVER strike a trolley intentionally to the stopper. -----

NEVER swing a suspended load. -----

NEVER weld or cut a load suspended by the trolley.

NEVER allow a trolley to collide with another trolley.

NEVER operate trolley unless load is centered under trolley. -----

3.2.3 After operation

NEVER leave a suspended load unattended.

NEVER throw a trolley.

3.2.4 Maintenance

ALWAYS let the qualified service personnel inspect the trolley periodically (Refer to 7.3).

3.2.5 Others

ALWAYS consult the manufacturer or your dealers if you plan to use a trolley in an excessively corrosive environment. (Salt water, sea air and/or acid, explosive environment or other corrosive compounds, etc.)

ALWAYS use a trolley within rail slope of 1 degree.

NEVER use a trolley which has been taken out of service until the trolley has been properly repaired or replaced. — — — — —

NEVER remove or obscure the warning stickers. — — — — —



4. MAIN SPECIFICATIONS

0.5 to 3 t

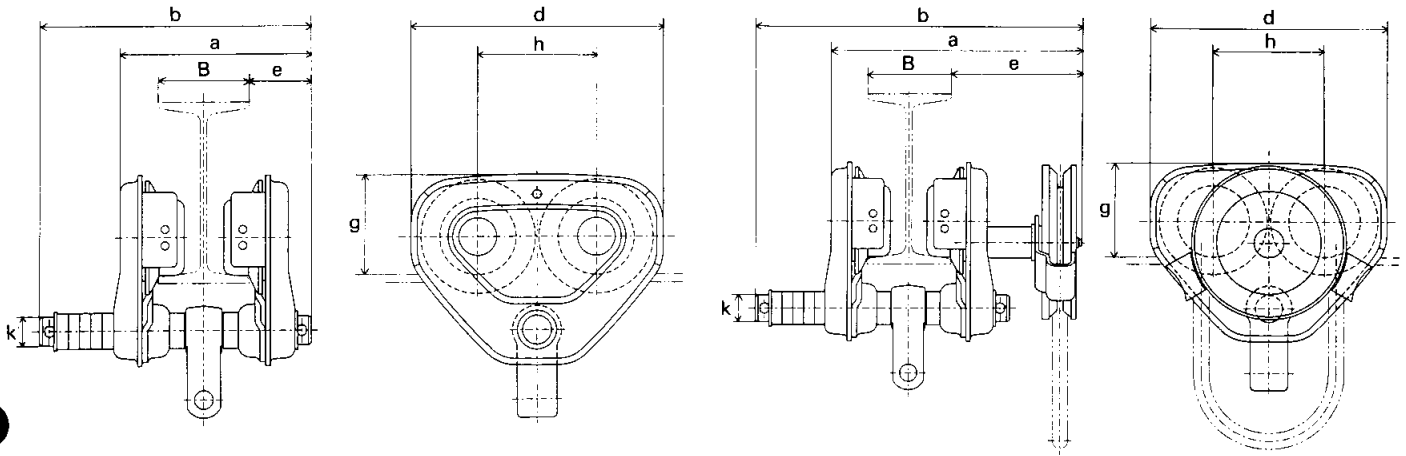

5 t

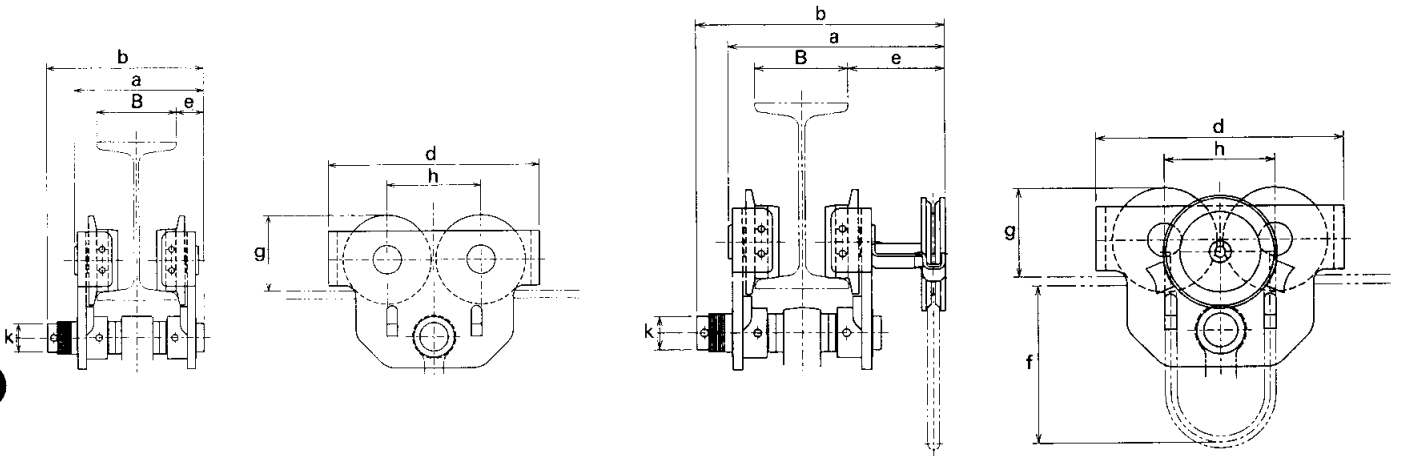

For manual chain hoist

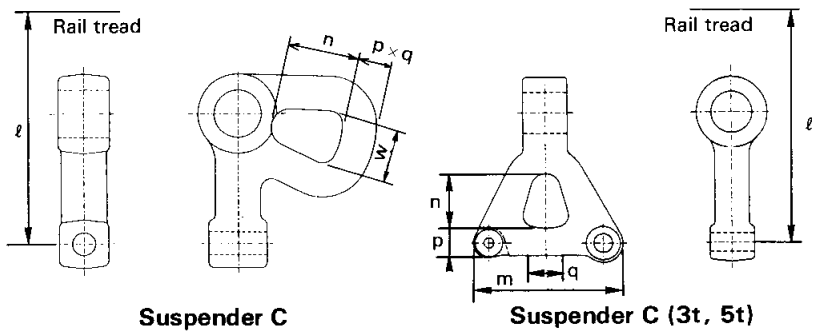

Suspender C

Suspender C (3t, 5t)

For electric chain hoist

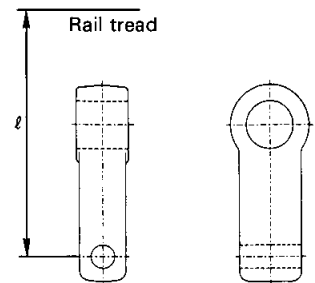

Suspender E,G

Code/C ⁽¹⁾ or E ⁽²⁾		WLL (t)	Rail width adjustability (mm)			Min radius for curve (mm)	Net weight (kg)		Hand chain folded length (m)		a [Max.] (mm)	
Plain trolley	Geared trolley		Standard	Option			TSP	TSG	C ⁽¹⁾	E ⁽²⁾	C ⁽¹⁾	E ⁽²⁾
				W20	W30							
TSP005C (E)	-	0.5	50 to 102	103 to 203	204 to 305	1100 ⁽³⁾	4.5	-	-	-	173	173
TSP010C (E)	TSG015C (E)	1	58 to 127	128 to 203	204 to 305	1300 ⁽³⁾	8	12	2.5	3	275 (215)	311 (215)
TSP015C	TSG015C	1.5	82 to 153	-	154 to 305	1500	14	18	2.5	2.5	349 (264)	-
TSP020C (E)	TSG020C (E)	2	82 to 153	-	154 to 305	1500	14	19	3	3	349 (264)	349 (264)
TSP025C (E)	TSG025C (E)	2.5	82 to 153	-	154 to 305	1700	23	27	3	3	359 (280)	359 (280)
TSP030C (E)	TSG030C (E)	3	82 to 153	-	154 to 305	1700	23	27	3	3	359 (280)	359 (280)
TSP050C (E)	TSG050C (E)	5	100 to 178	-	179 to 305	2300	50	56	3.5	3.5	376 (273)	376 (273)

Code/C ⁽¹⁾ or E ⁽²⁾		WLL (t)	b (mm)		d (mm)	e (mm)		f (m)		g (mm)	h (mm)	k (mm)	ℓ (mm)		m (mm)	n (mm)	p (mm)	q (mm)		
Plain trolley	Geared trolley		C ⁽¹⁾	E ⁽²⁾		C ⁽¹⁾	E ⁽²⁾	C ⁽¹⁾	E ⁽²⁾				C ⁽¹⁾	E ⁽²⁾					C ⁽¹⁾	E ⁽²⁾
TSP005C (E)	-	0.5	204	204	182	46	46	-	-	76	84	22	93	98	26	33	14	14		
TSP010C (E)	TSG010C (E)	1	309 (249)	345 (249)	236	116 (56)	152 (56)	2.2	2.7	95	112	25	106	-	28	37	18	18		
TSP015C	TSG015C	1.5	385 (300)	-	280	154 (69)	-	2.2	-	112	131	32	129	119	32	40	22	22		
TSP020C (E)	TFG020C (E)	2	385 (300)	385 (300)	280	154 (69)	154 (69)	2.7	2.7	112	131	32	129	138	32	40	22	22		
TSP025C (E)	TSG025C (E)	2.5	398 (320)	398 (320)	324	157 (79)	157 (79)	2.7	2.7	134	152	36	144	153	36	44	27	25		
TSP030C (E)	TSG030C (E)	3	398 (320)	398 (320)	324	157 (79)	157 (79)	2.7	2.7	134	152	36	169	153	40	48	24	30		
TSP050C (E)	TSG050C (E)	5	400 (297)	400 (297)	400	156 (53)	156 (53)	3.2	3.2	144	178	54	228	171	60	70	33	36		

Note : (1) C : For manual chain hoist.

(2) E : For electric chain hoist.

(3) Minimum flange width for curved rail:

(a) 0.5t trolley 57mm

(b) 1t trolley 73mm

(c) 2.5t and 3t trolley 89mm

Remark : 1) Figures in parentheses show the data for plain trolley type.

2) The maximum 200mm and 300mm rail width are available as option.

3) Net weight is when flange width is in standard range.

4) Dimension "a" is when flange width is adjusted to the maximum of the standard range.

5) Dimension "b" is when flange width is in standard range.

Allowable ambient conditions ;

Operation temperature : - 20°C to + 60°C

Operation humidity : 100%

5. INSTALLATION

5.1 Coupling with manual chain hoists

- (1) The M3 series hoist can be coupled either in the hook suspension method (the top hook is hung from the suspender C as shown in Fig. 5-1), or in the direct coupling method (the hoist body, with the top hook removed, is directly coupled to the suspender C as shown in Fig. 5-2).

However the 7.5t and larger capacity M3 series hoist can only be suspended by the hook suspension method and the top hook must be hung from the suspension shaft of the trolley.

The CF and CL series hoists can be suspended with suspender C like Fig. 5-3.

- (2) The hook suspension method type is best for circumstances when the chain hoist is transferred frequently.

The direct coupling method is best for circumstances which require as much effective hoisting length as possible, especially where the height of the ceiling is low.

- (3) Direct coupling method of M3 series chain hoist.

- (a) For 0.5 to 2.5t (Refer to Fig. 5-4)

- 1) Remove the wheel cover nuts and the spring washers, then remove the wheel cover.
- 2) Remove the split pin from the top pin, then remove the top pin and the top hook.
- 3) Mount the suspender C to the hoist body with the top pin and the split pin which have been removed as above.
- 4) Securely bend the split pin as shown in Fig. 5-5.
- 5) Install the wheel cover, as it was before, with the nuts and the spring washers.

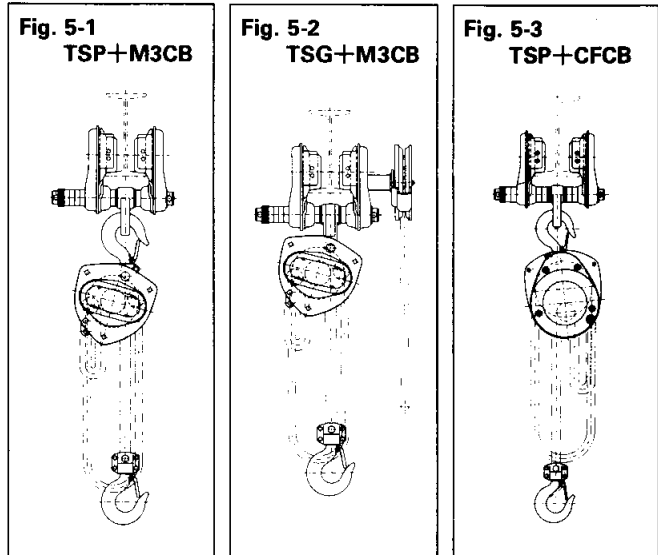

Fig. 5-4 Mounting suspender C

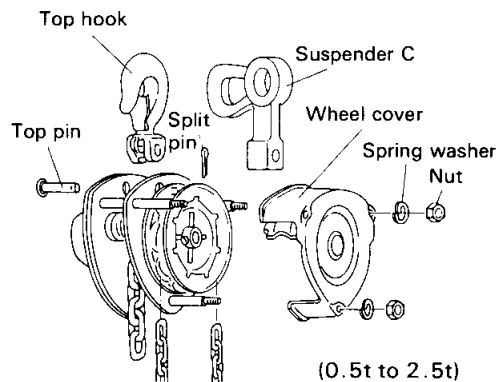
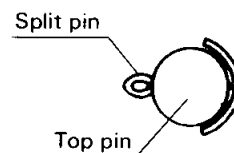

Fig. 5-5 Split pin bending



(b) For 3 or 5t (Refer to Fig. 5-6)

In addition to the procedure stated earlier, the following steps are also required.

- 1) Remove the split pin (from the slotted nuts), and then remove the slotted nut, the chain pin and the load chain from the top hook.
- 2) Connect the end of the load chain and the suspender C with the chain pin, the slotted nut and the split pin.
- 3) Bend securely the split pin.
- 4) Make sure that no twisting and no capsizing of the load chain occurs.

Fig. 5-6 Mounting suspender C

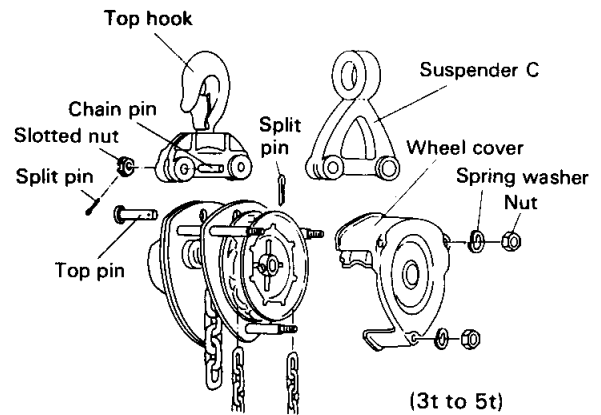

5.2 Coupling with electric chain hoists

5.2.1 ES, EF series

The direct coupling method shown in Fig. 5-9 should be applied.

- (1) Remove the split pin, the slotted nut and the top pin (in the case of double falls of the chain, the top bolt), and then remove the top hook. (Refer to Fig. 5-7).
- (2) Mount the suspender E to the hoist body with the top pin (or the top bolt) and the slotted nut which have been removed as above. Then insert a new split pin and bend it securely as shown in Fig. 5-5 on page 6.
- (3) The EF series electric chain hoist can be suspended by the suspender E like Fig. 5-10.

Fig. 5-7 Mounting suspender E

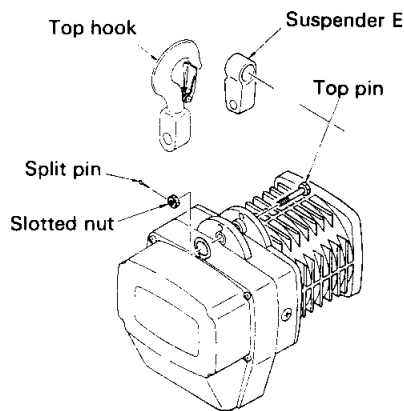
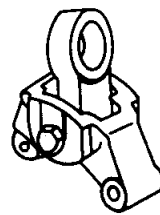

Fig. 5-8 Suspender for double chain falls hoist



Suspender E for double falls of chain

Fig. 5-9 TSG+ES

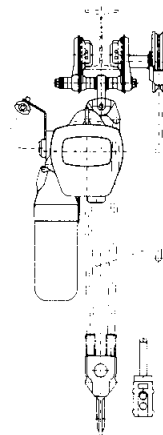
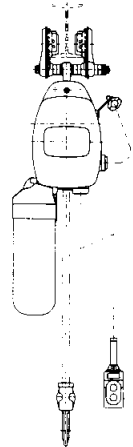

Fig. 5-10 TSP+EF



5.2.2 ER series

The direct coupling method shown Fig. 5-14 should be applied.

Mount the suspender G to the connection yoke with the connection yoke rubber, the yoke bolt and the slotted nut. (Refer to Fig. 5-13) Then insert a split pin and bend it securely as shown in Fig. 5-5.

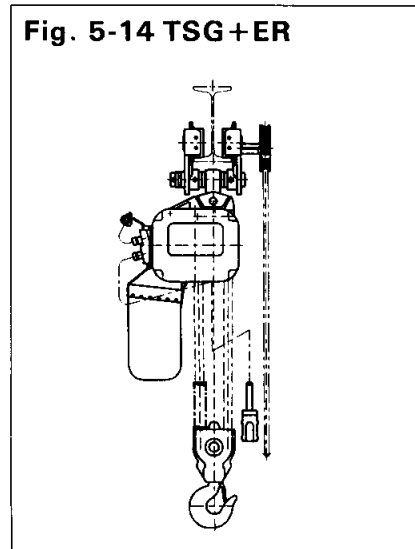
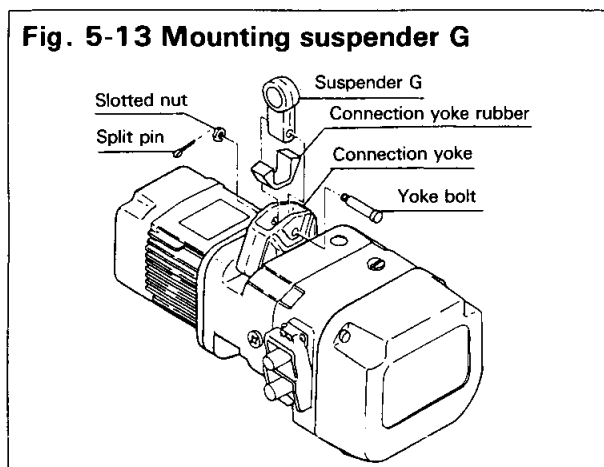

5.3 Adjusting trolley width before installation

When the trolley and the chain hoist are coupled, the trolley must be adjusted with the adjusting spacers (Refer to Table 5-1).

- (1) Make sure that the direction is as shown in Fig. 5-1, 5-2, 5-3, 5-9 or 5-10
- (2) The right and left side plates should be as far apart as possible, and the difference between A and B should be approximately 4mm (Refer to Fig. 5-11.)
- (3) Bend securely the split pin of the shaft stopper pin as shown in Fig. 5-12

Fig. 5-11 Trolley width adjustment

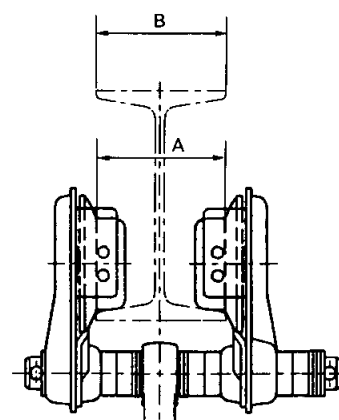

5.4 Installation of trolley onto beam

- (1) The preferred method of installation is from the end of the beam, with the chain hoist and the trolley coupled. After installation, make sure to re-install the stopper as it was.
- (2) When there is no space between the end of beam and building, first remove the side plate S (with name plate) from the suspension shaft. After placing the side plate G (or S without name plate) on the other side of the flange, re-assemble and re-install side plate S (with name plate) as it was before. Also, bend securely the split pin of the shaft stopper pin as shown in Fig. 5-12.

Fig. 5-12 Split pin bending

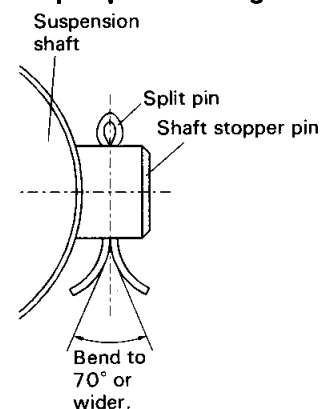

Remark : If using two or more trolleys on the same rail, separate them with a stopper between every two trolleys. Determine the distance between stoppers depending on site requirements, or contact KITO or a KITO authorized dealer for help.

5.5 Installation of stopper onto traversing beam

Make sure to install the stoppers at the both ends of the beam.

5.6 Check points after installation

When the entire installation is completed, check the following.

- (1) Check whether the relation between the positions of the trolley and the chain hoist is correct (Refer to Fig. 5-1 to 5-2, 5-3, 5-9 or 5-10).
- (2) Check that the beam stoppers are securely fastened on the rail to prevent trolley run away.
- (3) Make sure that no bolt, nut, split pin or snap pin is missing, and that these are all adequately fastened.

6. OPERATION

6.1 Intended purpose of trolley operation

⚠ WARNING

This trolley has been designed for horizontally transporting loads by hand, through manual or electric hoist under normal atmospheric conditions of the work place.

However, since dealing with heavy loads may involve unexpected danger, all the "Safety instructions" (Refer to 3.2) must be followed.

6.2 Safety working environment

⚠ WARNING

The operator must be aware of the following points while using the trolley.

- (1) The operator must have a clear and unobstructed view of the entire travel area before operating the trolley. When not possible, a second or more persons must serve as scouts in the nearby area.
- (2) The operator must check the entire travel area is safe and secure before operating the trolley.

6.3 Operation

⚠ CAUTION

ALWAYS take care hand or clothes not to be caught in a track wheel or other moving parts.

- (1) Plain trolley
The trolley movement is controlled by pushing the load or the hook of the attached hoist.
- (2) Geared trolley
 1. Face the hand wheel side of the trolley.
 2. To move left, pull hand chain clockwise.
 3. To move right, pull hand chain counterclockwise.

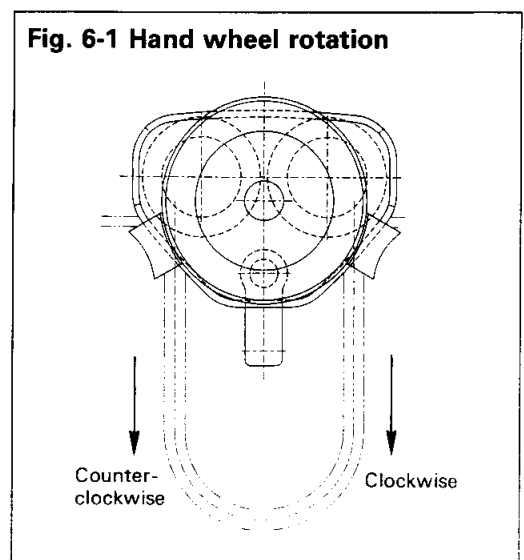

6.4 Trolley storage

⚠ CAUTION

Observe the following points when storing the trolley.

NEVER expose the trolley to rain or dew.

ALWAYS wipe off all dirt and water.

ALWAYS install in a dry place.

ALWAYS lubricate gear side of the pinion and track wheel G.

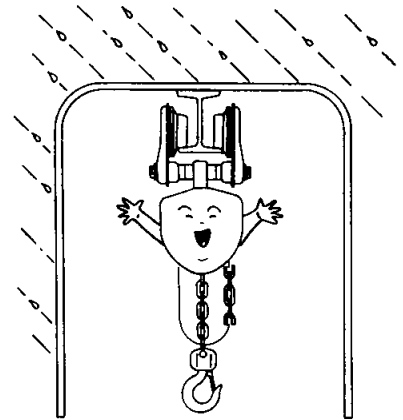

7. INSPECTION

7.1 Outline

There are two types of inspection, the daily inspection performed by the operator before using the trolley, and the more thorough periodic inspection performed by qualified service personnel who have the authority to remove the trolley from service.

7.2 Daily inspection

Before each work shift, check the following points :

Item	Inspection method	Discard limit/criteria	Remedy
1. Function	Run under no load condition.	Trolley should run smoothly and is not tilt when a light load is applied.	If the movement is not smooth, try to determine its cause and replace the trolley with a new one if necessary.
2. Wear, deformation and damage of each part	Check visually.	There should be no wear, deformation or damage.	Replace the part with new one if worn, deformed or damaged.
3. Part loosening	Check visually.	Parts should not be loosened.	Fasten tightly.
4. Name plate	Check visually.	Every description should be clear and visible.	Replace the name plate with new one.
5. Hand chain	Check visually.	There should be no deformation or damage.	Replace the chain.
	Listen to the noise.	There should be no irregular noises.	Replace the chain or inspect the hand wheel.
6. Missing of parts	Check visually.	No missing nuts and/or split pins.	Replace the parts.

7.3 Periodic inspection

Periodic inspection shall be made at the interval shown below and should follow the given procedures.

- NORMAL (Normal use) : Semiannual inspection
 HEAVY (Frequent use) : Quarterly inspection
 SEVERE (Excessively frequent use) : Monthly inspection

Inspect all the items in "Periodic inspection" in addition to "Daily inspection" items.

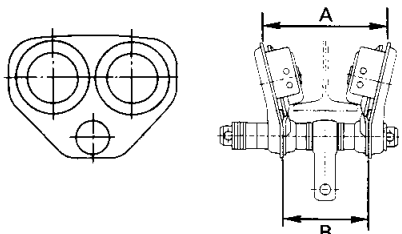
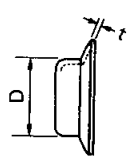
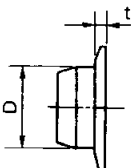
Item	Inspection method	Discard limit/criteria	Remedy																																		
1. Traversing function	Move trolley with light load suspended.	Trolley should run smoothly, and not tilt when a light load applied. Overall movement should be smooth.	If not smooth, adjust beam, re-adjust balance or lubricate pinion holder, pinion and gear of track wheel G.																																		
2. Side plate deformation	Check with calipers.	The difference of dimension "A" and "B" should not exceed 2mm. 	If the difference exceeds 2mm, replace it with a new one.																																		
3. Track wheel wear	Check visually or use calipers as needed. For 0.5 to 3t  For 5t 	Wear of flange tread should not be less than the limits on the table below. <table border="1" data-bbox="744 1489 1372 1780"> <thead> <tr> <th rowspan="2">WLL (t)</th> <th colspan="2">Larger tread diameter : D</th> <th colspan="2">Flange thickness : t</th> </tr> <tr> <th>Standard</th> <th>Limit</th> <th>Standard</th> <th>Limit</th> </tr> </thead> <tbody> <tr> <td>0.5</td> <td>60</td> <td>58.5</td> <td>3.2</td> <td>2.5</td> </tr> <tr> <td>1</td> <td>71</td> <td>69.5</td> <td>4</td> <td>3.3</td> </tr> <tr> <td>2</td> <td>85</td> <td>83.5</td> <td>4.5</td> <td>3.8</td> </tr> <tr> <td>3</td> <td>100</td> <td>98.5</td> <td>5</td> <td>4.3</td> </tr> <tr> <td>5</td> <td>118</td> <td>112</td> <td>9.6</td> <td>6.7</td> </tr> </tbody> </table>	WLL (t)	Larger tread diameter : D		Flange thickness : t		Standard	Limit	Standard	Limit	0.5	60	58.5	3.2	2.5	1	71	69.5	4	3.3	2	85	83.5	4.5	3.8	3	100	98.5	5	4.3	5	118	112	9.6	6.7	Replace it with a new one if it is less than the limit.
WLL (t)	Larger tread diameter : D			Flange thickness : t																																	
	Standard	Limit	Standard	Limit																																	
0.5	60	58.5	3.2	2.5																																	
1	71	69.5	4	3.3																																	
2	85	83.5	4.5	3.8																																	
3	100	98.5	5	4.3																																	
5	118	112	9.6	6.7																																	
4. Damage of hand wheel	Check visually.	NEVER use the damaged one.	Replace it with new one.																																		

Item	Inspection method	Discard limit/criteria	Remedy
5. Deformation and wear of gear (track wheel G, pinion)	Check visually or use calipers as needed.	NEVER use the deformed or worn one.	Replace it with new one.
6. Deformation and wear of suspension shaft	Check visually or use calipers as needed.	NEVER use the suspension shaft if its diameter is worn by 10% or more.	Replace it with new one.
7. Wear of suspender	Check visually or use calipers as needed.	NEVER use the suspender if its dimension of " D_2-D_1 " or " d " exceeds the limit in the table below. NEVER use the suspender if dimension " h " is less than the limit in the table below.	Replace if it exceeds the limit. Replace if it is less than the limit.

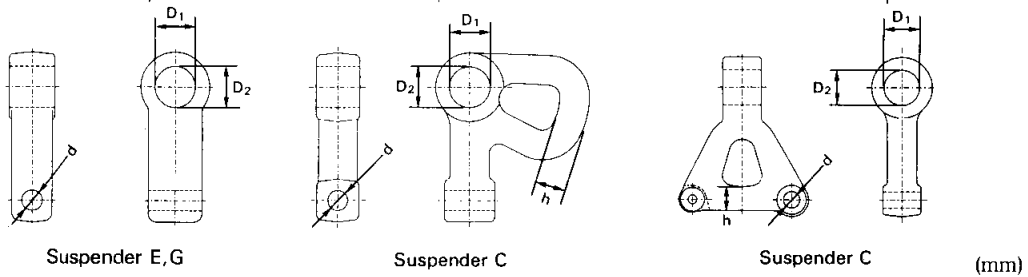

Hoist type	WLL (t)	Hoist capacity (t)	$D_2 - D_1$ limit	d		h	
				Standard	Limit	Standard	Limit
				(mm)			
CB (Susp. C)	0.5	0.5	1	12.2	13	14	12.5
	1	0.5, 1	1	12.2	13	18	16
	2	1.5, 1	1	16.2	17	22	20
	3	2.5	1.5	16.2	17	27	24
		3	1.5	16.4	17	24	21.5
5	5	1.5	16.4	17	33	30	
ES or EF (Susp. E), ER (Susp. G)	0.5	0.25, 0.5-S, 0.5-L	1	12.2	13	-	-
	1	1-S, 1-L	1	12.2	13	-	-
	2	1.5, 2-S, 2-L	1	20.2	21	-	-
	3	2.5, 2.8, 3	1.5	20.2	21	-	-
	5	5	1.5	28.2	30	-	-

8. Rail deformation	Check visually or use calipers as needed.	The flange should not be deformed.	Replace or repair.
9. Condition of welded part	Check visually.	There should be no crack. There should be no rust.	Repair or strengthen.
10. Rail wear	Check visually or use calipers as needed.	The tread should not be worn. Replace it if the dimension " B " becomes 95% or " t " becomes 90% of new one.	Replace.

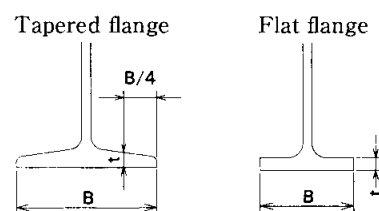

Item	Inspection method	Discard limit/criteria	Remedy
11. Condition of wheels	Check visually.	The trolley wheels should track the beam properly. Total clearance between wheels and flange equals 4mm.	Adjust or repair. Adjust the clearance if necessary.
12. Loosening of fixing bolt	Try to turn it with a spanner.	The bolt should be tightened firmly.	Tighten the bolt.
13. Missing of rivets, split pins and nuts	Check visually.	Parts should not be missing.	Replace the missing parts.

8. MAINTENANCE

⚠ WARNING

- (1) **NEVER** perform maintenance on the trolley while it is supporting a load.
- (2) Before performing maintenance, attach the tag ;
[“DANGER” : **NEVER** OPERATE EQUIPMENT BEING REPAIRED.]
- (3) Only allow qualified service personnel to perform maintenance.
- (4) After performing any maintenance on the trolley, **ALWAYS** test to WLL before returning to service.

⚠ CAUTION

ALWAYS take care hand or clothes not to be caught in a track wheel or other moving parts.

8.1 Lubrication

8.1.1 Geared wheels (geared trolley only)

Lubricate exposed trolley drive pinion and wheel teeth. Brush with grease as often as necessary to keep teeth liberally covered. If the grease becomes contaminated with sand, dirt or other worn materials, remove old greases and replace with new grease (standard grease⁽¹⁾) during monthly or annual inspection.

Temperature range of standard grease is -20°C to $+60^{\circ}\text{C}$.

If the trolley is used at temperature below -20°C or above $+60^{\circ}\text{C}$, consult KITO or authorized KITO dealer since some parts shall be changed.

Remark : ⁽¹⁾ Calcium soap grease equivalent of NLGI(National Lubricating Grease Institute)/ # 2 or EP 2.

8.1.2 Trolley wheels and hand chain

Trolley wheel bearings do not need to be lubricated and must be replaced if worn or damaged. Hand chain, used on geared trolleys, do not normally requires lubrication.

8.2 Overhaul and assembly

Overhaul and assembly should be performed with reference to the following Fig. 8-1 or 8-2.

- (1) For overhauling a geared trolley, remove the track wheel first, then take off the pinion.
- (2) Adjusting spacers and fixing spacers can be classified by colour.
Adjusting spacers : Yellow
Fixing spacers : White
- (3) In case that the geared trolley is coupled with the manual or electric chain hoist, the trolley's hand chain should be on the right side facing the hoist's name plate side.
- (4) Bend the split pin securely as shown in Fig. 8-1 or 8-2 after the installation is completed.
- (5) Place the shaft stopper pin as shown in Fig. 8-1 or 8-2, the flat surface should be touched on adjusting spacers.

Fig. 8-1 Trolley parts arrangement—for 3 t and smaller

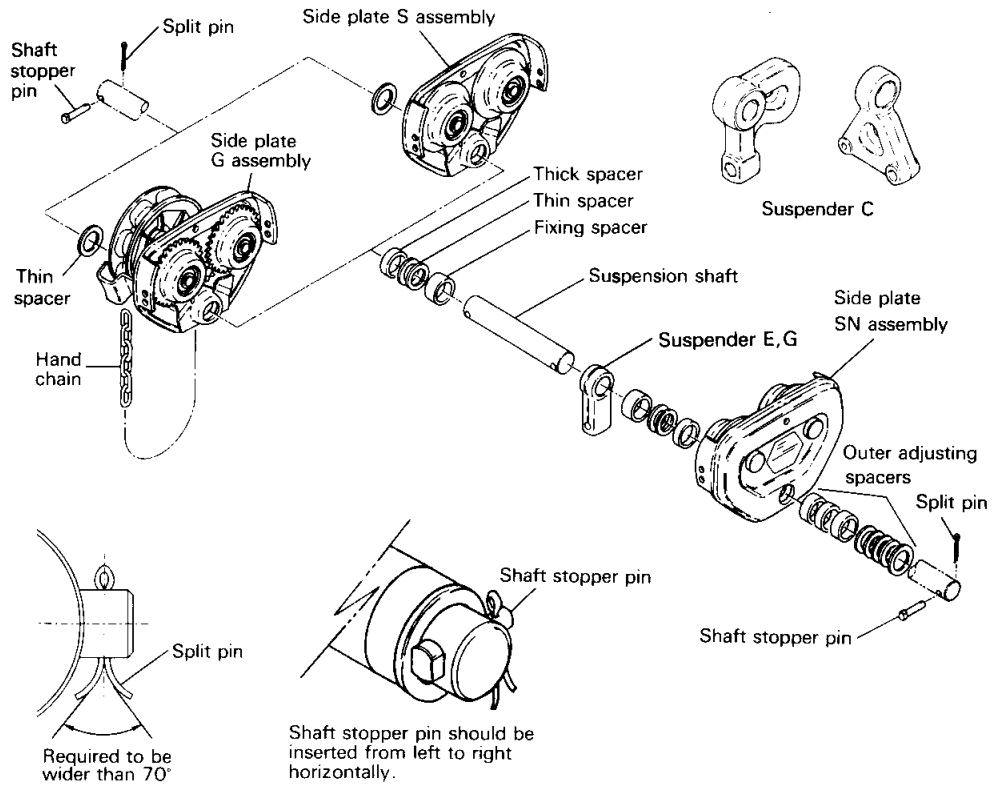
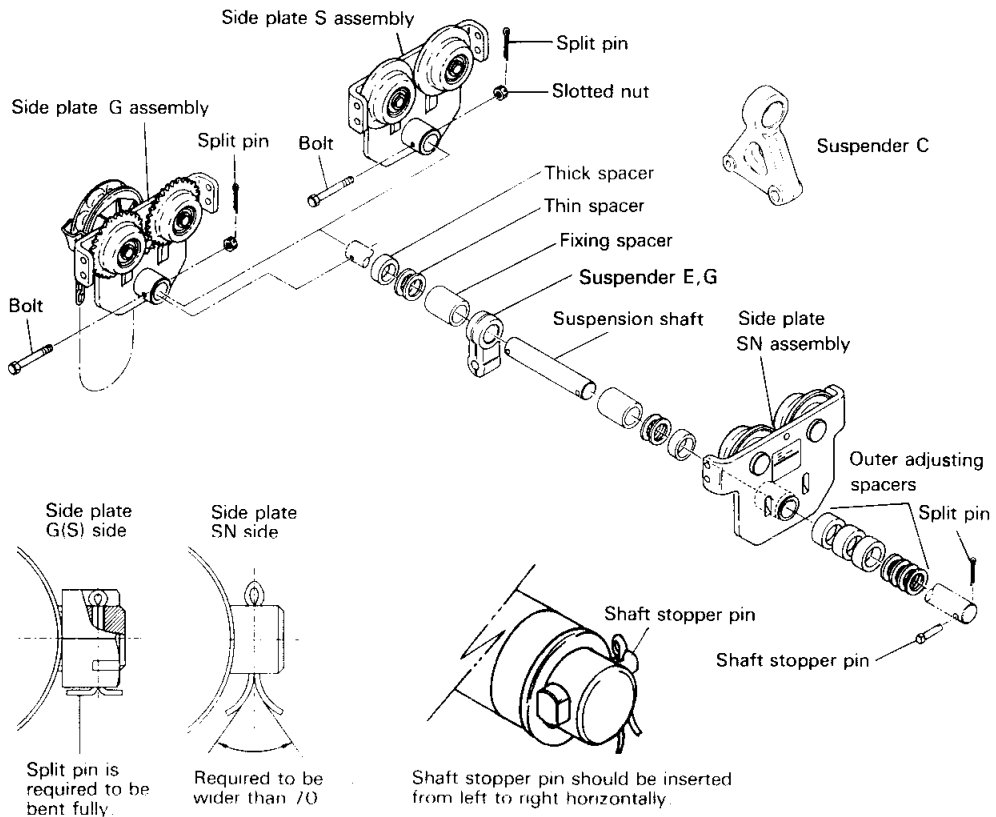

Fig. 8-2 Trolley parts arrangement—for 5 t



9. OPTIONAL BUFFER

9.1 Buffer

The side plate "S", "SN" and "G" have bumpers which prevent damage to the wheel and to the trolley. Buffers are available as option.

9.1.1 Installation of buffer

Assemble as described below. Tighten the screw securely so the buffer can not be moved by hand.

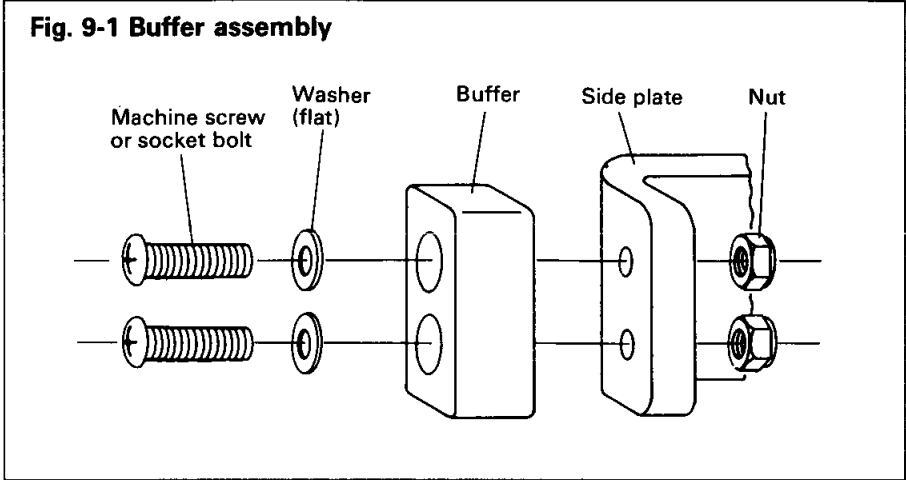

10. WARRANTY

KITO Corporation ("KITO") extends the following warranty to the original purchaser ("Purchaser") of new products manufactured by "KITO"(KITO's Products).

- (1) "KITO" warrants that KITO's Products, when shipped, shall be free from defects in workmanship and/or materials under normal use and service and "KITO" shall, at the election of "KITO", repair or replace free of charge any parts or items which are proven to have said defects, provided that all claims for defects under this warranty shall be made in writing immediately upon discovery and, in any event, within one (1) year from the date of purchase of KITO's Products by "Purchaser" and provided, further, that defective parts or items shall be kept for examination by "KITO" or its authorized agents or returned to KITO's factory or authorized service center upon request by "KITO".
- (2) "KITO" does not warrant components of products provided by other manufacturers. However to the extent possible, "KITO" will assign to "Purchaser" applicable warranties of such other manufacturers.
- (3) Except for the repair or replacement mentioned in (1) above which is "KITO"'s sole liability and purchaser's exclusive remedy under this warranty, "KITO" shall not be responsible for any other claims arising out of the purchase and use of KITO's Products, regardless of whether "Purchaser"'s claims are based on breach of contract, tort or other theories, including claims for any damages whether direct, indirect, incidental or consequential.
- (4) This warranty is conditional upon the installation, maintenance and use of KITO's Products pursuant to the product manuals prepared in accordance with content instructions by "KITO". This warranty shall not apply to KITO's Products which have been subject to negligence, misuse, abuse, misapplication or any improper use or combination or improper fittings, alignment or maintenance.
- (5) "KITO" shall not be responsible for any loss or damage caused by transportation, prolonged or improper storage or normal wear and tear of KITO's Products or for loss of operating time.
- (6) This warranty shall not apply to KITO's Products which have been fitted with or repaired with parts, components or items not supplied or approved by "KITO" or which have been modified or altered.

THIS WARRANTY IS IN LIEU OF ALL OTHER WARRANTIES, EXPRESS OR IMPLIED, INCLUDING BUT NOT LIMITED TO ANY WARRANTY OF MERCHANTABILITY OR OF FITNESS FOR A PARTICULAR PURPOSE.

11. PARTS LIST

When ordering replacement parts please specify WLL, Fig. No., part No., part name and quantity.

Plain trolley (Rail width—standard)

Fig. 12-1 Parts development—3t and smaller plain trollies (for normal rail width)

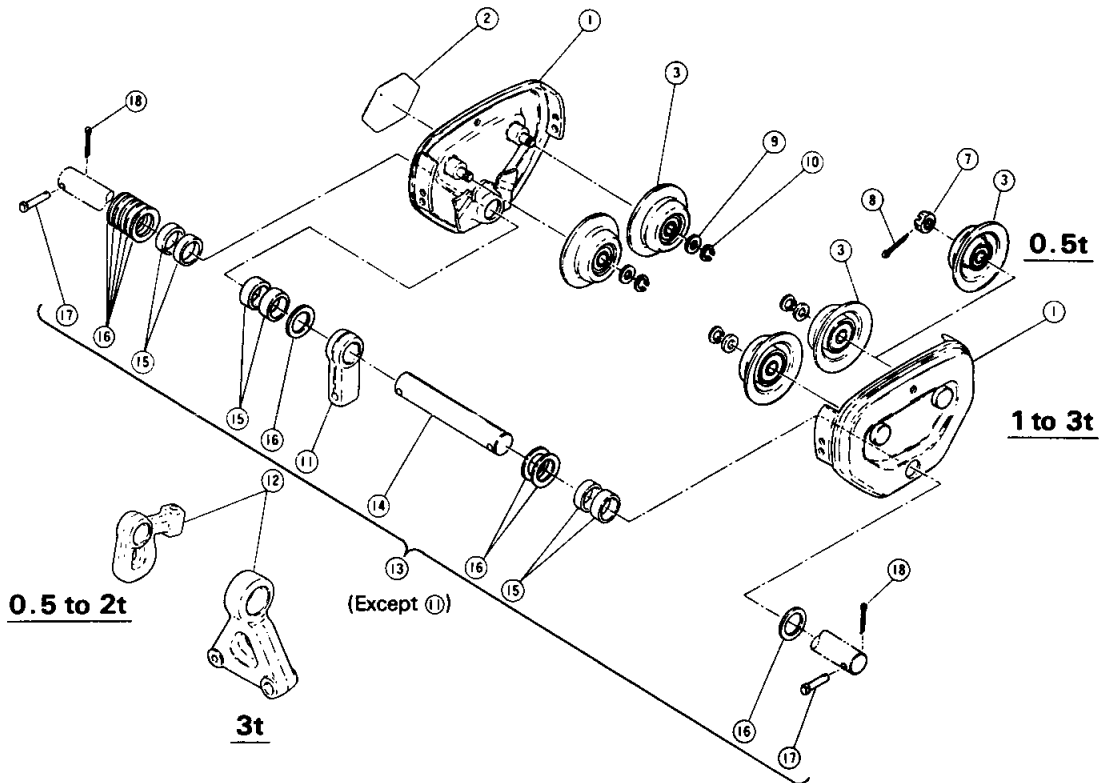

Fig. 12-2 Parts development—5t plain trolley (for normal rail width)

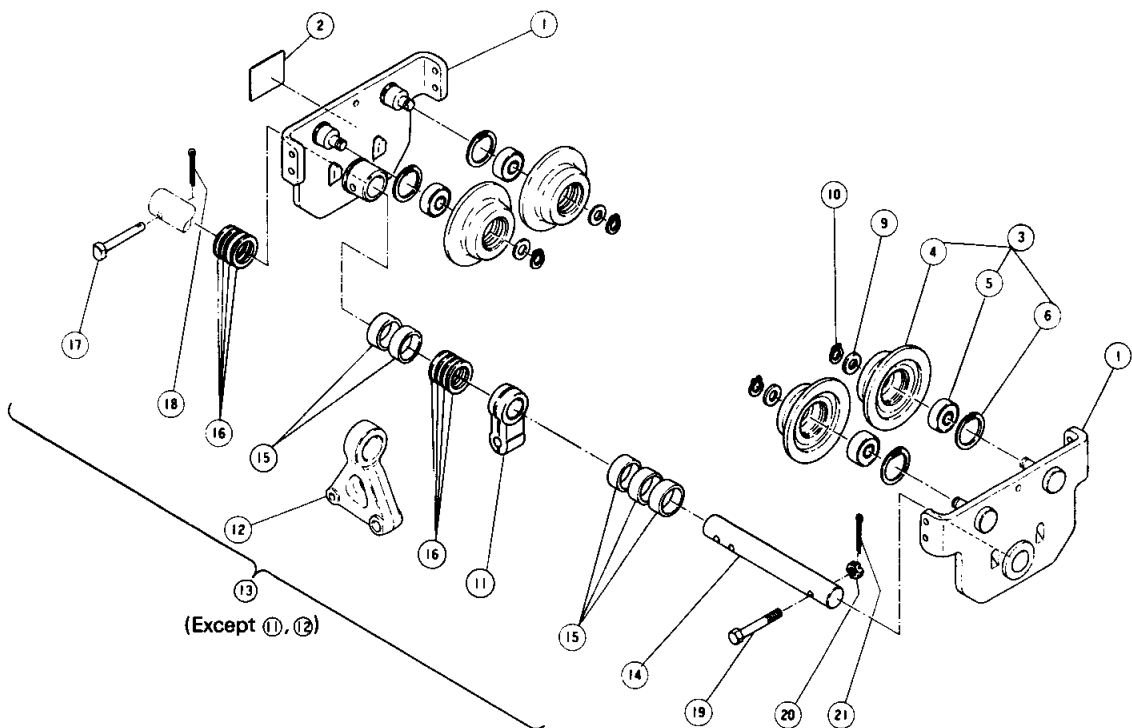

Fig. No.	Part No.	Part name	Nos. per trolley	WLL (t)					Remarks
				0.5	1	2	3	5	
1		Side plate S assembly	2					—	
		Side plate S assembly	2	—	—	—	—		
2	T7G-800	Name plate B	1						
3	T6G-5102	Track wheel S assembly	4					—	
	T3G-1102	Track wheel S assembly	4	—	—	—	—		
4		Track wheel S	4	—	—	—	—		
5		Ball bearing	4	—	—	—	—	(6307ZZ)	
6		Snap ring	4	—	—	—	—	(R-80)	
7	T6P-158	Slotted nut	4	(L-M10)	—	—	—	—	
8	T6P-159	Split pin	4	(2 × 16)	—	—	—	—	
9	T6G-104	Track wheel washer	4	—		(TIG-2 [†])	(TIG-3 [†])	(MS3-5 [†])	
10	T6G-106	Snap ring	4	—	(S-15)	(S-20)	(S-25)	(S-35)	
11	T7GB-004	Suspender E, G	1					(MS3-5 [†])	for Electric chain hoist
12	T7GC-004	Suspender C	1					(T5G-5 [†])	for Manual chain hoist
13	T7G-1115	Suspension shaft (standard) assembly	1						
14	T7G-115	Suspension shaft (standard)	1						
15	T7G-116	Thick spacer	(a)					(TIG-5 [†])	
16	T7G-117	Thick spacer	(b)					(MS3-5 [†])	
17	T6G-156	Shaft stopper pin	2 (1)					(MS3-5 [†])	(1) for 5 t
18	T6G-157	Split pin	2 (1)	(3.2 × 20)		(4 × 20)		(4 × 22)	(1) for 5 t
19	T4G-154	Suspension shaft bolt	1	—	—	—	—	(MS3-5 [†])	
20	T4G-155	Slotted nut	1	—	—	—	—	(L-M12)	
21	T4G-156	Split pin	1	—	—	—	—	(3 × 22)	

Note : (a) 4p'cs for 0.5t, 6p'cs for 1t-2t, 9p'cs for 3t, 5p'cs for 5t.

(b) 10p'cs for 0.5t, 9p'cs for 1t, 8p'cs for 2t-5t, 11p'cs for 3t.

: Parts given no part No. are not to be supplied independently.

Geared trolley (Rail width-standard)

Fig. 12-3 Parts development-3 t and smaller geared trolleys

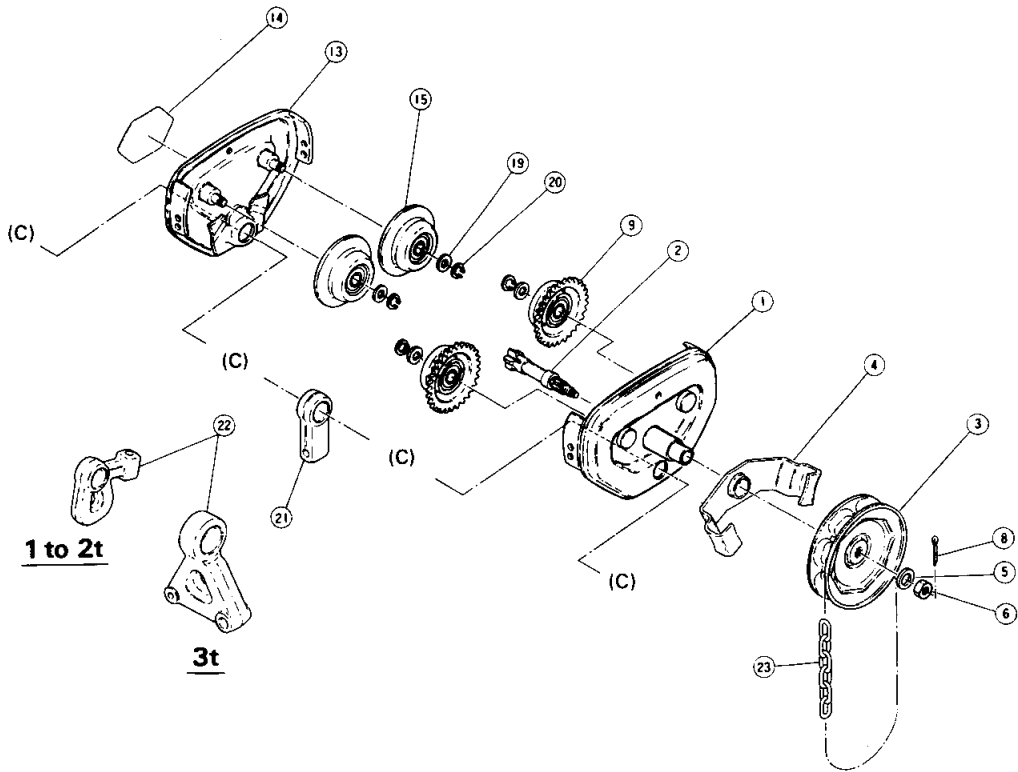
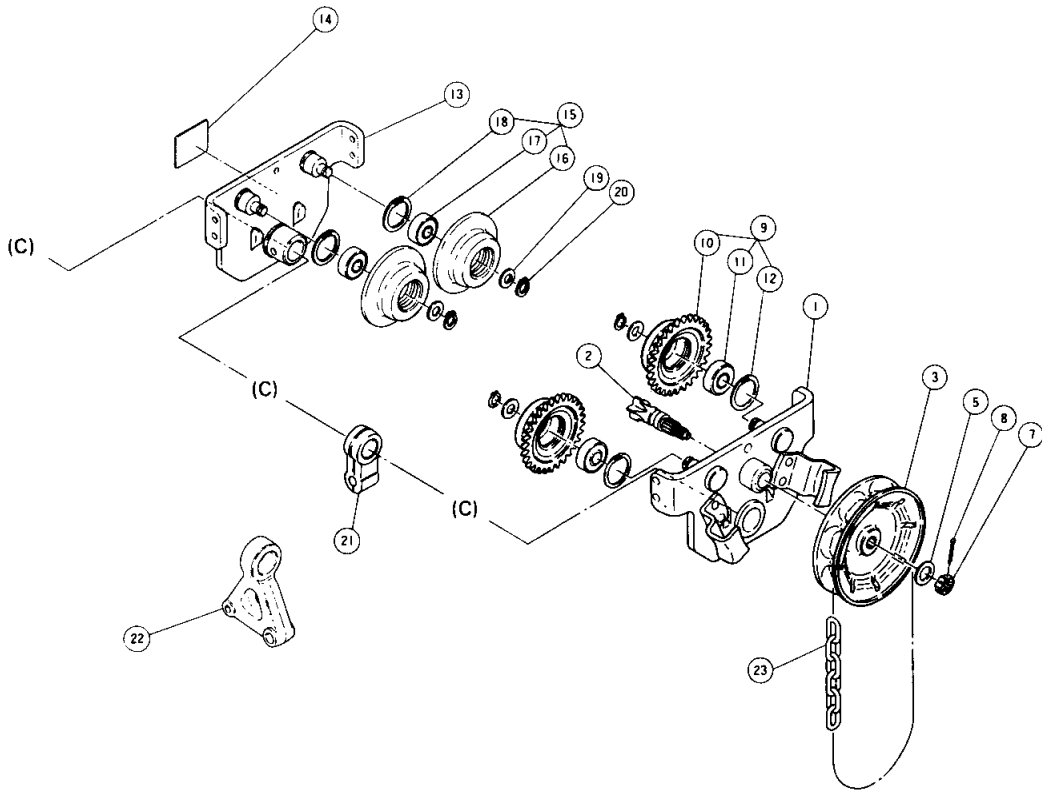

Fig. 12-4 Parts development-5 t geared trolley



Note : (c) Refer to the parts list of plain trolley for suspender assembly.

Fig. No.	Part No.	Part name	Nos. per trolley	WLL (t)				Remarks
				1	2	3	5	
1	T7G-5111	Side plate G assembly	1				—	
	T5G-5111	Side plate G assembly	1	—	—	—		
2	T7GB-127	Pinion	1	—			(T4GB-1 ^h)	
			1		—	—	—	for Electric chain hoist
	T7GC-127	Pinion	1		—	—	—	for Manual chain hoist
3	T6G-123	Hand wheel	1					
4	T6G-5125	Hand chain guide assembly	1				—	
5	T7G-152	Washer	1	(L-M12)				
6	T7G-151	Lever nut	1	(M2-40 ^h)			—	
7	T4G-151	Slotted nut	1	—	—	—	(L-M12)	
8	T7G-160	Split pin	1	(3 × 18)			(3 × 22)	
9	T6G-5101	Track wheel G assembly	2				—	
	T4G-1101	Track wheel G assembly	2	—	—	—		
10	T4G-101	Track wheel G	2	—	—	—		
11	T4G-107	Ball bearing	2	—	—	—	(6307ZZ)	
12	T4G-105	Snap ring	2	—	—	—	(R-80)	
13	T7G-5112	Side plate S assembly	1				—	
	T5G-5112	Side plate S assembly	1	—	—	—		
14	T7G-800	Nama plate B	1					
15	T6G-5102	Track wheel assembly	2				—	
	T4G-1102	Track wheel S assembly	2	—	—	—		
16	T4G-101	Track wheel S	2	—	—	—		
17	T4G-107	Ball bearing	2	—	—	—	(6307ZZ)	
18	T4G-105	Snap ring	2	—	—	—	(R-80)	
19	T7G-104	Track wheel washer	4		(TIG-2 ^h)	(TIG-3 ^h)	(MS3-5 ^h)	
20	T7G-106	Snap ring	4	(S-15)	(S-20)	(S-25)	(S-35 ^h)	
21	T7GB-004	Suspender E, G	1				(MS3-5 ^h)	for Electric chain hoist
22	T7GC-004	Suspender C	1				(TS1-5 ^h)	for Manual chain hoist
23	T7G-842	Hand chain	1					

Rail width-option

Fig. 12-5 Suspension shaft W20 assembly. (0.5 t, 1 t)

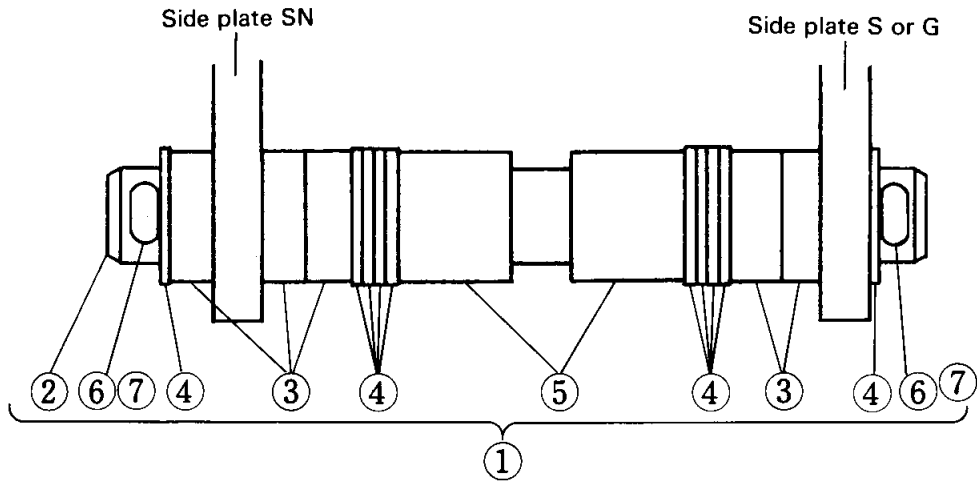

Fig. 12-6 Suspension shaft W30 assembly. (0.5 t, 3 t)

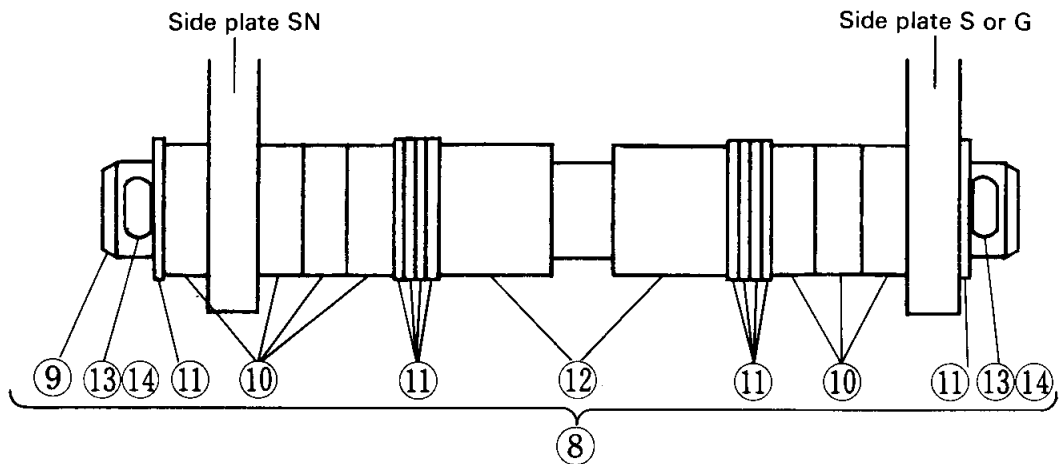

Fig. 12-7 Suspension shaft W30 assembly. (5 t)

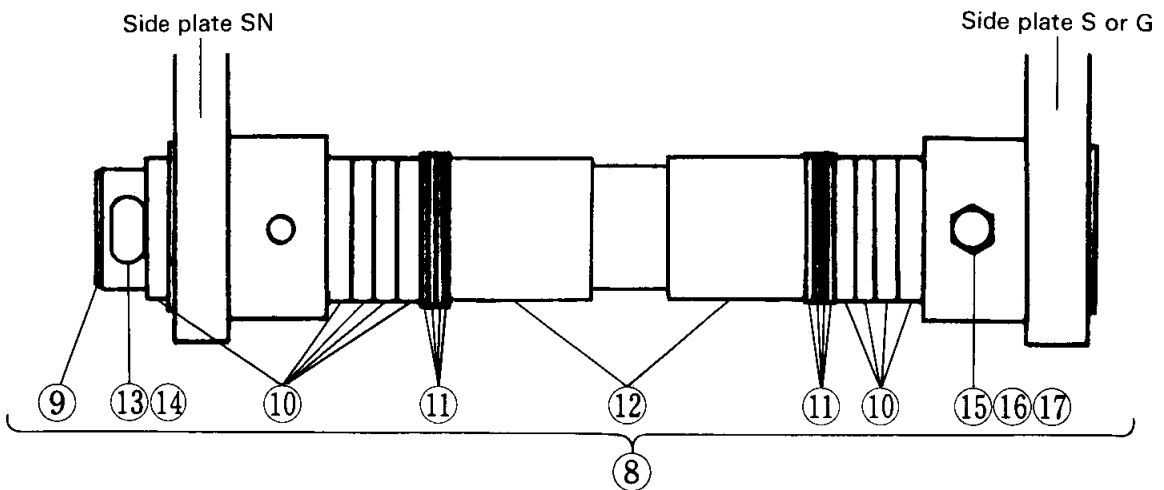

Fig. No.	Part No.	Part name	Nos. per trolley	WLL (t)					Remarks
				0.5	1	2	3	5	
1	T7G-1136	Suspension shaft W20 assembly	1			—	—	—	
2	T7G-136	Suspension shaft W20	1			—	—	—	
3	T7G-116	Thick spacer	(d)			—	—	—	
4	T6G-117	Thin spacer	10			—	—	—	
5	T7G-137	Fixing spacer W20	2			—	—	—	
6	T6G-156	Shaft stopper pin	2			—	—	—	
7	T6G-157	Split pin	2	(3.2 × 20)		—	—	—	
8	T7G-1181	Suspension shaft W30 assembly	1					—	
9	T7G-181	Suspension shaft W30	1						
10	T7G-116	Thick spacer	(e)					(T1G5 ¹)	
11	T6G-117	Thin spacer	10 (8)					(MS3-5 ¹)	(8) for 5 t
12	T7G-182	Fixing spacer W30	2						
13	T6G-156	Shaft stopper pin	2 (1)				(MF2-2 ¹)	(MS3-3 ¹)	(1) for 5 t
14	T6G-157	Split pin	2 (1)	(3.2 × 20)		(4 × 20)		(4 × 22)	(1) for 5 t
15	T4G-154	Shaft stopper pin	1	—	—	—	—	(MS3-5 ¹)	
16	T4G-155	Slotted nut	1	—	—	—	—	(L-M12)	
17	T4G-156	Split pin	1	—	—	—	—	(3 × 22)	

Note : (d) 7p'cs for 0.5t, 5p'cs for 1t.

(e) 7p'cs for 0.5t-1t, 11p'cs for 2t-3t, 9p'cs for 5t.



KITO CORP.

3-37-4, Yoyogi, Shibuya-ku,

Tokyo 151-0053, Japan

Tel. : 03-5371-7341

Fax. : 03-5371-7349

Tlx. : 222-2942 KITO J

E-mail : overseas@kito.co.jp

URL [http : //www.kito.co.jp](http://www.kito.co.jp)